

Interactive Constraint-Based Space Layout Planning

Shikder, S.

Department of Civil and Building Engineering, Loughborough University
(s.h.shikder@lboro.ac.uk)

Price, A.

Department of Civil and Building Engineering, Loughborough University
(a.d.f.price@lboro.ac.uk)

Mourshed, M.

Department of Civil and Building Engineering, Loughborough University
(m.m.mourshed@lboro.ac.uk)

Abstract

Layout planning is the primordial design activity that determines the characteristics and performance of a building throughout its lifecycle. Due to its iterative nature, there is a growing interest in the automation of space layout planning to enhance the search for optimum design solutions. The approaches for automation range from constraint/heuristics-based to the application of numerical optimisation algorithms. Among these, the use of design constraints to guide the search of the solution space is well regarded due to its ability to model design problems of an applied nature with multiple objectives. Constraint-based approaches also allow interactivity between the designer and layout planning process, which simulates the iterative nature of creative design and can be integrated well with the existing design process. Interactivity also enhances the management of design knowledge through improved processing and visualisation of information. This paper presents a theoretical framework for interactive constraint-based layout optimisation with an implemented prototype for a hospital patient room interior layout. The theoretical framework was developed by analysing existing layout automation methods and interactive approaches through a review of relevant literature. Object-oriented computer programming was used to develop the prototype to demonstrate the proposed approach of interactive layout planning system. The framework augments the iterative design process by facilitating the active participation and sharing of the designer's knowledge during the aggregation. With regard to the implementation of the framework in large problems, fast evaluation of design solution was found to be necessary to interact with the system in real time. Interactive constraint-based layout optimisation has, therefore, the ability to enhance the search process of optimum design solutions by augmenting the iterative nature of the creative design process.

Keywords: interactivity, layout planning, constraint based space optimisation.

1. Introduction

Layout planning is the primordial design activity that determines the characteristics and performance of a building throughout its lifecycle. The process of evidence-based design in layout planning embodies the design concepts based on logic, learning, grammar, constraints, reasoning, etc. To incorporate the myriad of representation, an effective mechanism for the modelling, sharing and visualising the design information is essential. Due to its iterative nature, there is a growing interest in the automation of space layout planning to enhance the search for optimum design solutions. The approaches for automation range from constraint/heuristics-based to the application of numerical optimisation algorithms. Among these, the use of design constraints to guide the search of the solution space is well regarded due to its ability to model design problems of an applied nature with multiple objectives. Constraint-based approaches also allow interactivity between the designer and layout planning process, which simulates the iterative nature of creative design and can be integrated well with the existing design process. Interactivity also augments the management of design knowledge through improved visualisation and processing of information. Interactivity has been implemented in a few earlier layout generation systems to mimic the iterative process of design or as a method of constraint modification process (Ruch 1978; Ligette & Mitchell 1981; Calderon et al. 2003; Michalek & Papalambros 2002). This paper presents a theoretical framework of method of interactive layout automation and attempts to apply the theory through the development of a prototype. The application was aimed at the design of an interior layout of a hospital patient room.

2. Background

2.1 Layout automation theories and methods

Layout generation is dependent on functional requirements and relationships between spaces. Eastman (1973) described, in such problems, topographical relationships (e.g. adjacency, alignment, grouping) and other functional/physical properties (such as shape, dimension, distance, etc.) are of principal concern. Typical problems include floor plan layout, arrangement of equipments in the room, site planning and other forms of two-dimensional design tasks (Eastman 1973; Baykan & Fox 1992). Several approaches and techniques have been applied in automated space layout problems over the years. Liggett (2000) conceptualised the representation of space as discrete objects (one-to-one assignment problem), space as area (many-to-one assignment problem) and space as area and shape (blocking or floor plan layout problem).

Quadratic assignment is the earliest formulation of the architectural spatial synthesis problems and applied to many one-to-one assignment problems. The approach was first initiated by Koopmans and Beckmann in 1957 (Mitchell 1977). The formulation was applied where circulation cost or some directly analogous objectives were to be minimised. The approach can be viewed as a combinatorial problem where functions or spaces are to be allocated in fixed locations. The formulation calculates all possible ways of assigning activities and then selects the plan which satisfies all given constraints

or conditions. In practice, this method is infeasible to solve a problem with large number of activities or functions (problems over 15 activities) since the calculation becomes vast (Jagielski & Gero 1997; Tate & Smith 1995). Genetic Algorithm and Simulated Annealing are also two other solution procedures widely used in quadratic assignment problem (Liggett 2000; Mitchell 1977).

Unequal area problems can be considered more similar to architectural layout problems, which takes place during the earlier phase of the design. Two approaches found noteworthy in unequal area arrangements are Graph Theories or Adjacency Requirement Graph Formulation and Constraint Based Approaches. An approach of using Genetic search is also found by Tate and Smith (1994). In Graph theories, adjacency between the spaces are considered during solution procedures. A resulting output is a block plan as the dual of a planar graph where nodes represent spaces and links represent required adjacencies (Mitchell 1977; Goetschalckx 1992). Constraint based approaches are based on the definite requirements of the definite spaces. The approach considers multiple objectives and the output is generally given by rectangular shapes. Two types of constraints are usually needs to be satisfied in this approach:

- Dependent on structure or topology of the problem. Such as, spaces should not cross the boundary.
- Independent on structure and consider attributes such as, dimension, orientation, proportions etc.

The approach has several types of methods in strategy and calculation. Three potential methods are LOOS – a hierarchical generate and test approach (Fleming et al. 1992); WRIGHT – a spatial synthesis approach by disjunctive constraint satisfaction (Baykan & Fox 1992); and HeGeL – Heuristics generation of layouts (Akin et al. 1992).

2.2 Previous studies in interactive layout automation/optimisation

Interactive approaches integrate designer knowledge and experience in the computation process and generally considered to be more useful in decision-making. Interactive approaches also augment the iterative process of design. An early example is Liggett and Mitchell's (Liggett & Mitchell 1981) approach in spatial allocation task. The problem was formulated as a quadratic assignment problem and the objective was to minimise a cost function associated with the activities in a particular layout. Through the graphical interface designer receives expected output value of objective function, which can integrate the cost of the location with other design considerations not incorporated in a mathematical solution. In this process the designer was interactively able to integrate information through a keyboard and light-pen; visual aid was provided by a low-resolution color or grey-scale raster graphics terminal. This problem was particularly focused on the communication efficiency of a floor plan layout. Another early example is by Ruch (1978), which is based on a graph theoretic approach where the architectural plan was divided into three levels of abstract representations: the graph, the bubble diagram and the schematic plan. In this demonstration, the interactive approach was intended to track the traditional design process by prompting appropriate questions in various stages.

Starting with a graph of linked spaces, the representation was then transformed to a bubble diagram and finally converted to a schematic plan.

SEED-Layout (SL) is another example, which generates schematic building layouts including schematic site design. Based on LOOS/ABLOOS system the project established constraint based approach as a strong expression of decision support system in construction (Flemming & Chien 1995; Calderon et al. 2003). For interactivity SEED environment contained different windows based on applications. Problem Specification Window (PSW) is the interface between the designer and the problem specification component of the module. Design and the Evaluation Windows were interfaces for communicating with designer and the generation and evaluation component. Design Space Window (DSW) was showing different states of generation in breadth (how many alternatives have been generated) and depth (how many units have been allocated). A concept of third dimension was existing in this interface declared as Multidimensional Design Space, which was showing old design solutions and was used to modify problem specifications.

Design of these interfaces has gone through some evaluations for clarity of information and command buttons. SEED-Layout incorporated iterative process by incorporating user interaction in above mentioned states through ‘tree figures’, but evaluation by users about the interface suggested a more visual representation of space and information manipulation including better retrace ability of previous steps (Flemming & Chien 1995). An attempt to design interface for interactive layout generation system is found by (Chinowsky & Teicholz 1993) for Computer Aided Architectural Design Expert (CAADIE) project, which was constituting requirement windows to address analysis actions, output window to contain synthesized results and evaluation charts for evaluation feedback. The interface represented spatial configuration in schematic bubble diagrams and evaluation charts with bar graphs, and provided opportunity to explore multiple solutions.

Comparatively recent example is found from Michalek and Papalambros (2002) in interactive layout automation. This constraint based approach supports iterative design process by user/designer interactivity in step by step modification and optimisation approach. The method provides controlling of multiple actions like addition, deletion and modification of objectives, constraints, units and incorporates interactivity in defining the problem, guiding the search and exploring the design space. The problem type was targeted a one floor layout of an apartment complex comprising three flats. Another example found by Calderon et al. (2003) through a virtual environment interface. The approach based on Unreal Tournament™ game engine as interactive 3D environment and used Constraint Logic Programming to manipulate movable and non-movable constraints. This method allows user participation in defining movable constraints and evaluate alternative solutions through automated decision generation, but limits in multiple constraint modification by user. This method has expressed interactive representation of design knowledge and space rather than build up iterative design process, but certainly demonstrated a new approach of designer/user interaction in intelligent virtual environment compared to predecessor prototypes.

Ozkaya and Akin (2006) emphasized on information consistency and traceability in requirement driven design. The authors proposed a framework for required driven design process and a mechanism to build digital design thinking process called requirement-design coupling (RDC), which

demonstrates concept of visualising design and requirement space simultaneously for direct and implied dependency cases.

One of the objective of interactive layout generation/optimisation is formulating iterative design process. Design process involves creativity and the very activity of human mind and body. Iterative process can be different for individuals and engage own developed practice. From this concept it is difficult to devise ultimate evaluation of these prototypes without employing in real practice. However they have produced rigorous understanding of solution procedures and extent of computational efficiency in architectural layout problem.

2.3 Desired interactive environment

Discussion of previous section revealed few issues to consider in developing a practicable interactive layout generation program for future, they are,

- Representation of continuous information;
- Visualisation and manipulation of design information;
- System and interface design to support iterative design process.

Updated and continuous information visualisation is an essential part to form the iterative process of design by affording ability to revise previous decisions. Storing of generated and modified design information is required to revisit previous solutions, which demand a systematic database structure. As software and hardware environment advanced in storing, manipulating and retrieving design data, there is scope to think how digital design information will be synthesized and how designers will think about the design information (Ozkaya & Akin 2006). Oxman (2008) also stated existing theories of design needs re-consideration with the change of professional techniques due to influence of digital methodologies.

Interface design can play significant role in layout automation programs by providing improved information visualisation and manipulation ability. However, considerably less studies are found in case of interface system design. Rational use of the developed user interaction techniques can bring advantage of dealing the problem simultaneously with the machine, where interactivity can constitute design knowledge management through designer's own knowledge and experience. Also effective interaction through input and output facilities can determine the way how designer uses the system (Chinowsky 1993). Liggett (2000) emphasized that program interface should be able to prepare and present data at any desired level of aggregation and use output from one stage of the design process to generate sub-problems at the next stage.

3. Proposed prototype

A layout automation program has been proposed and developed partly, which can assist in spatial design of a hospital patient room interior. The objective of the prototype is to explore a strategy of solving spatial configuration problem of the particular space type, where the designer gets the opportunity to participate interactively in decision making process in parallel with the computer to derive rational solution. The prototype is aimed to meet mentioned facilities discussed in preceding section to assist in iterative design process. After completion of the prototype, it will be distributed among the practicing architects/designers and an evaluation will be made based on suggestions/comments received from architects/designers.

3.1 Problem definition

The target problem was a standard single bed in-patient accommodation. Space standards were adopted from Health Building Note 04 (DH Estates and Facilities Division 2008). Equipment and furniture information were acquired from Activity Database (Department of Health 2009). The patient room was equipped with the following spatial elements: bed, wash basin, work table, seat/bed, easy chair, storage (for patient), bedside table and locker. Arrangements of internal furniture and equipments of a patient room are based on specific logics to meet functional requirements. Additionally there are definite conceptions and considerations about the adjacencies and links of the individual elements.

According to Health Building Note 04-01(DH Estates and Facilities Division 2008) a patient room should be sound ergonomically for easy access of staff and equipments to support clinical activity. Also importance is posed on occasional observations of patients by staff from corridors for safety reasons. Position of bed demands the most concentration during design and can be influenced by accessibility, observation, patient's view through the window, etc. Bed head panel, over-bed table and bedside table/locker are directly adjacent to the bed. Location of other elements also demand specific consideration based on functions. Such as, wash basin should offer easy access for nurse and bin should be immediate to the wash basin. For ease of calculation these elements were grouped together as one space-object in this study. Detail recommendations for the spatial configuration can be found in Department of Health Activity Database (Department of Health 2009) and In-patient accommodation: Options for choice Health Building Note 04-01 (DH Estates and Facilities Division 2008), which were followed to solve the problem in this prototype.

3.2 Selection of optimisation approach

A hierarchy based constraint satisfaction approach was used as the optimisation method for this problem. The method can be described as Gradient based approach. One of the primary reason to select this method is necessity of faster calculation to support real-time participation of the designer with the system. Also the method is well recognised for its robustness in constraint based space layout optimisation. Application of extended search method (where search method evaluates all

possible solutions) or population based approaches (e.g. genetic algorithm) are expensive in calculation time, which can create delayed response to support active participation of the designer/user in real-time interaction.

3.3 Information manipulation

Design information is the key element to set up the logical behaviour of spatial objects. Three types of information were used to derive design solution. The first type of information was the topological definition and can be declared as global constraints. This included site area and orientation and were fixed throughout the design process. The second type of information declared the state of individual objects. These variables were changed during the design process dependent on others state and adjacency logic. The third type of information was dependent on user input which defined the variable state of objects. These set of variables were captured during the manipulation by user/designer to form the iterative process. Logical processing of these three types of information generated the design decision. Another type of information was stored in the database, which were captured during generation of each solution including user modifications. This information was not processed through any logical behaviour, however the user was able to retrieve this data at later stage for revisiting previous options.

3.4 Prototype configuration

Space-objects were represented by vector graphic drawings and bounded by invisible rectangular shapes defined by four variables (Figure 1). The context of the design problem was converted into constraints to force organisation of the space-objects. The process started with an initial constraint satisfaction, and then proceed to satisfy other constraints based on configured hierarchy. A graphical user interface (GUI) provided interactive communication between the user and the computer application (Figure 2). The following aspects were considered during the design of the GUI:

- Representation of site definition and space-objects;
- Users' ability to define/modify site information (e.g. dimension, orientation, etc.);
- Users' ability to manipulate spatial objects; and
- Real-time or continuous information visualisation for traceability and interactivity.

User/designer interaction provided opportunity to modify design constraints. The GUI provided opportunity to define room dimensions and space-object parameters (e.g. location, orientation, size, etc.). When space-objects were moved by designer/user, the program overrided computed decisions for particular parameters and recalculated the problem.

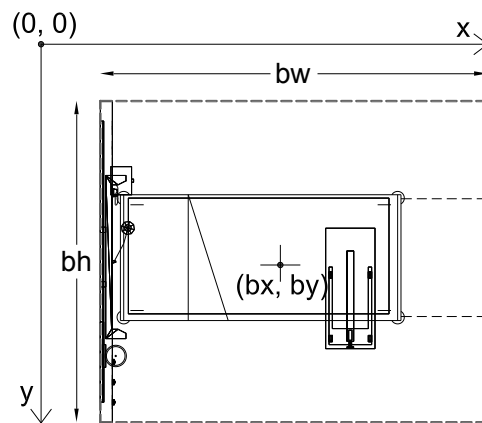

Figure 1: Representation of a space-object (patient bed) by four variables.

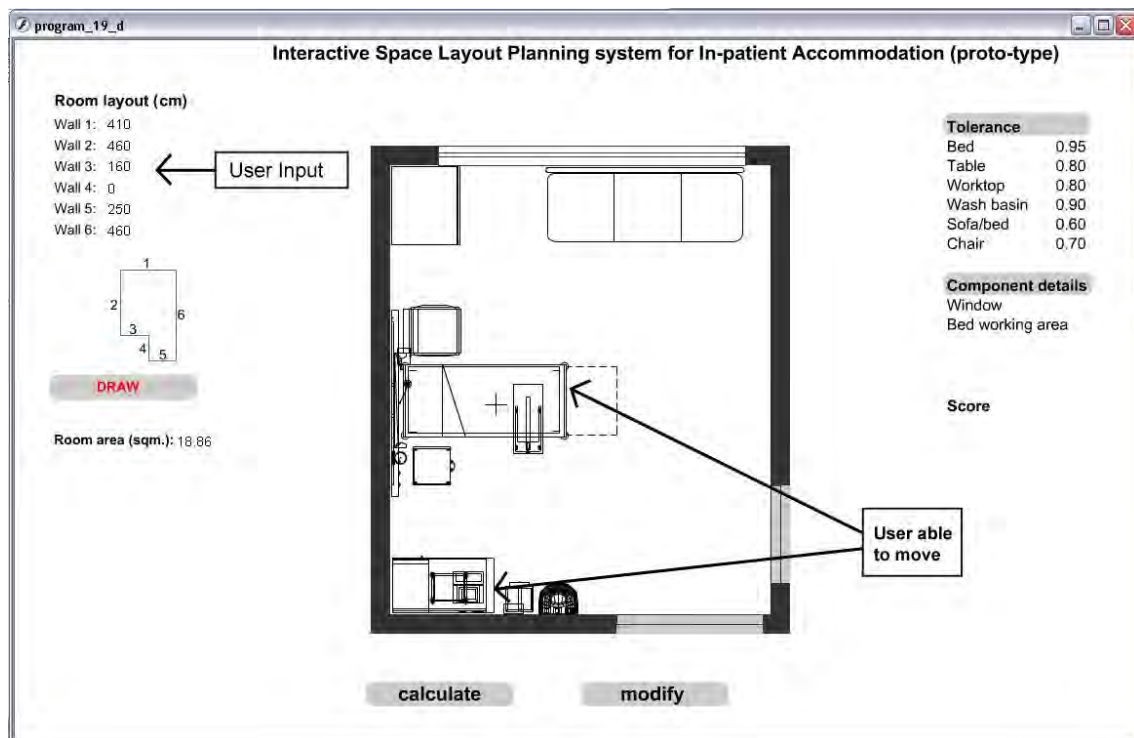

Figure 2: The prototype interface showing user interactivity.

3.5 Interactive automation process

The designer starts by defining global constraints (room dimension) followed by the door positions through the GUI. A layout can be generated with these information by 'calculate' command. At this stage designer can move or resize space-objects based on own preference and knowledge. Such as position of bed is redefined to ensure better outside view through the window. In this situation the

'modify' command re-generates layout by positioning other spatial elements considering new position of the bed and other constraint factors. Each calculated and modified layout generated by the application is saved in database, which can be accessed by user anytime during the iterative process through a separate floating window.

4. Discussion and conclusion

This paper presented an approach of using interactivity in layout automation programs based on constraint satisfaction method. The proposed prototype is a demonstration of computer aided design (CAD) environment with built-in intelligence that generates design decision for a specific building type. The prototype also integrated interactivity to enhance the information exchange and improved the designer's participation in decision making process in parallel with the computer optimisation, and attempted to form the iterative process of design. Framework for the interactive approach was proposed by critical review of previous interactive layout automation programs to identify the persuasive method.

The prototype has used the concept of evidence-based design to guide the spatial reasoning for internal layout of a hospital patient room. Logic behind the spatial configuration was adopted from the guidelines on hospital space standards to demonstrate its applicability in a realistic setting. It has been found that providing interactivity during layout automation requires faster calculation with real-time visualisation. Constraint based approach used in this prototype reduces search process significantly using pre-defined design constraints and hierarchy. Interactivity was provided through a graphical user interface (GUI), which was allowing constraint modifications and participation in the decision making process in real-time. This approach allowed designer to manipulate design constraints with ease within the interface and offered rapid evaluation of alternative solutions This process forms an integral part of design exploration, computationally which can reduce the number of iterations and increase the feasibility of design solutions.

The GUI also visualise the design output with multiple indicators to help in assessing design performance for the generated solution. As architectural design development and delivery process is expressed through a visual representation (Meniru et al. 2003; Cross 1999), deliberate concentration was necessary to develop the GUI in a CAD environment. Proposed GUI in this prototype afford ability to interact through hardware device in real time during the aggregation and forms the information exchange between human and computer. The developed GUI can be defined as an intelligent design space to support the decision making, which is applicable by physical involvement.

The approach of this prototype has few limitations which can demand attention during the interactive automation process. Results obtained by gradient based method is generative based on configured hierarchy, where initial constraint satisfaction is important to eliminate biased or faulty result. This stipulate the importance of defining and satisfying initial constraint appropriately to guide the entire evolution procedure. Opportunity remains to explore other optimisation methods in interactive approach which will be covered in future studies. Again design explorations do not necessarily remain fixed throughout the process and can demand change of constraints. Interactivity was

providing opportunity to modify constraint parameters, however there was no option to add or delete constraints in this version. Incorporation of these options can strengthen the design exploration, on the contrary will increase calculation load and data handling complexity.

It can be suggested that integration of layout automation methods and design data through interactivity can formulate desired software environment to assist in initial spatial problem solution. In this paper a framework to implement a prototype has been discussed and evaluated based on a partially implemented prototype, which identified issues require further attention in future developments.

References

Akin, O., Dave, B., Pithavadian, S. 1992, "Heuristic generation of layouts (HeGeL): based on a paradigm for problem structuring", *Environ. Plan. B: Plan. Des.*, vol. 19, pp. 33-59.

Baykan, C.A. & Fox, M.S. 1992, "WRIGHT: a constraint based spatial layout system" in *Artificial intelligence in engineering design: design representation and models of routine design* Academic Press Professional, Inc, pp. 395-432.

Calderon, C., Cavazza, M. & Diaz, D. 2003, "A new approach to virtual design for spatial configuration problems", IEEE Computer Society, pp. 518.

Chinowsky, P. & Teicholz, P. 1993, "The design of user interfaces for intelligent layout generation systems", *Design Studies*, vol. 14, no. 3, pp. 247-260.

Cross, N. 1999, "Natural intelligence in design", *Design Studies*, vol. 20, no. 1, pp. 25-39.

Department of Health 2009, , *Activity Database: The briefing, design & commissioning tool for both new-build and refurbishment of healthcare buildings*, [Online]. Available: <http://www.adb.dh.gov.uk/> [2010, January] .

DH Estates and Facilities Division 2009, *Health Building Note 04-01: Adult in-patient facilities*, DH Estates, UK.

Eastman, C.M. 1973, "Automated Space Planning", *Artificial Intelligence*, vol. 4, pp. 41-64.

Flemming, U., Baykan,C.A., Coyne, R.F., Fox, M.S. 1992, "Hierarchical generate-and-test vs. constraint-directed search: A comparison in the context of Layout Synthesis", *Proceedings of the Artificial Intelligence in Design Conference '92*, Kluwer, Dordrecht, pp. 817-838.

Flemming, U. & Chien, S.F. 1995, "Schematic layout design in SEED environment", *Journal of Architectural Engineering, ASCE*, vol. 1, no. 4, pp. 162-169.

- Goetschalckx, M. 1992, "An interactive layout heuristic based on hexagonal adjacency graphs", *European Journal of Operational Research*, vol. 63, no. 2, pp. 304-321.
- Jagielski, R. & Gero, J.S. 1997, "A Genetic Programming Approach To The Space Layout Planning Problem", *CAAD FUTURES*, vol. 875, pp. 875--884.
- Liggett, R.S. 2000, "Automated facilities layout: past, present and future", *Automation in Construction*, vol. 9, no. 2, pp. 197-215.
- Liggett, R.S. & Mitchell, W.J. 1981, "Interactive graphic floor plan layout method", *Computer-Aided Design*, vol. 13, no. 5, pp. 289-298.
- Meniru, K., Rivard, H. & Bédard, C. 2003, "Specifications for computer-aided conceptual building design", *Design Studies*, vol. 24, no. 1, pp. 51-71.
- Michalek, J.J. & Papalambros, P.Y. 2002, "Interactive Design Optimization of Architectural Layout", *Eng. Opt.*, vol. 34, no. 5, pp. 485-501.
- Mitchell, W.J. 1977, *Computer-Aided Architectural Design*, John Wiley Sons, Inc, New York, NY, USA.
- Oxman, R. 2008, "Digital architecture as a challenge for design pedagogy: theory, knowledge, models and medium", *Design Studies*, vol. 29, no. 2, pp. 99-120.
- Ozkaya, I. & Akin, Ā. 2006, "Requirement-driven design: assistance for information traceability in design computing", *Design Studies*, vol. 27, no. 3, pp. 381-398.
- Ruch, J. 1978, "Interactive space layout: A graph theoretical approach", IEEE Press, Las Vegas, Nevada, United States, pp. 152.
- Tate, D.M. & Smith, A.E. 1994, "Unequal Area Facility Layout Using Genetic Search", *IIE TRANSACTIONS*, vol. 27, pp. 465--472.
- Tate, D.M. & Smith, A.E. 1995, "A Genetic Approach to the Quadratic Assignment Problem", *Computers and Operations Research*, vol. 22, no. 1, pp. 73-83.